

RECOMMENDED MOUNTING HOLE PATTERN FOR 1.78 MAX THICK P.C. BOARD COMPONENT SIDE SHOWN

- 1 MATERIAL:
HOUSING: NYLON, UL94V-2 (COLOR - NATURAL, COLOR OF PARTS MAY VARY).
CONTACTS: 0.25 THK COPPER ALLOY.
- 2 CONTACT FINISH: 0.003 MIN THK TIN-LEAD OVER 0.00127 MIN THK NICKEL OVER ENTIRE CONTACT.
- 3 CONTACT FINISH: 0.00076 MIN THK GOLD PLATE ON PIN MATING SURFACE, 0.003 MIN THK TIN-LEAD PLATE ON SOLDER TAIL, ALL OVER 0.00127 MIN THK NICKEL BASE PLATE.
- 4. SOLDER TAIL MEETS AMP SOLDERABILITY SPECIFICATION 109-11-2.
- 5. MATES WITH SIMILARLY PLATED AMP-DUAC™ POWER CONNECTOR RECEPTACLE HOUSINGS/SOCKET CONTACTS.
- 6 RIBS ON FOUR CORNERS OPTIONAL.
- 7 AMP LOGO AND MATERIAL ID MAY BE LOCATED ON EITHER LONG SIDE OF PART.
- 8 SIZE, SHAPE OR STYLE OF THIS FEATURE MAY VARY.
- 9 CONTACT FINISH: 0.003 MIN THK TIN OVER 0.00127 MIN THK NICKEL OVER ENTIRE CONTACT.
- 10 CONTACT FINISH: 0.00076 MIN THK GOLD PLATE ON PIN MATING SURFACE, 0.003 MIN THK TIN PLATE ON SOLDER TAIL, ALL OVER 0.00127 MIN THK NICKEL BASE PLATE.

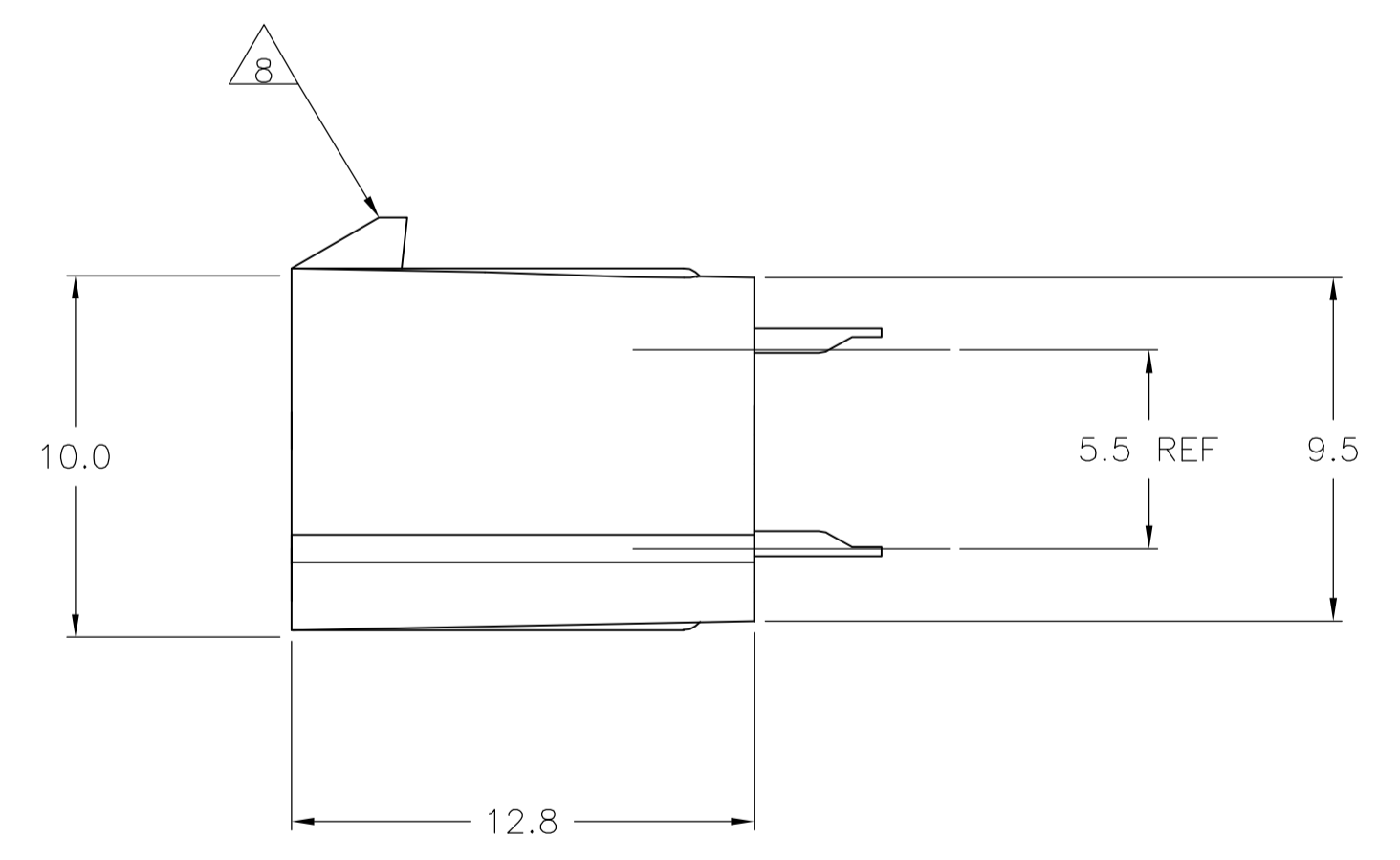
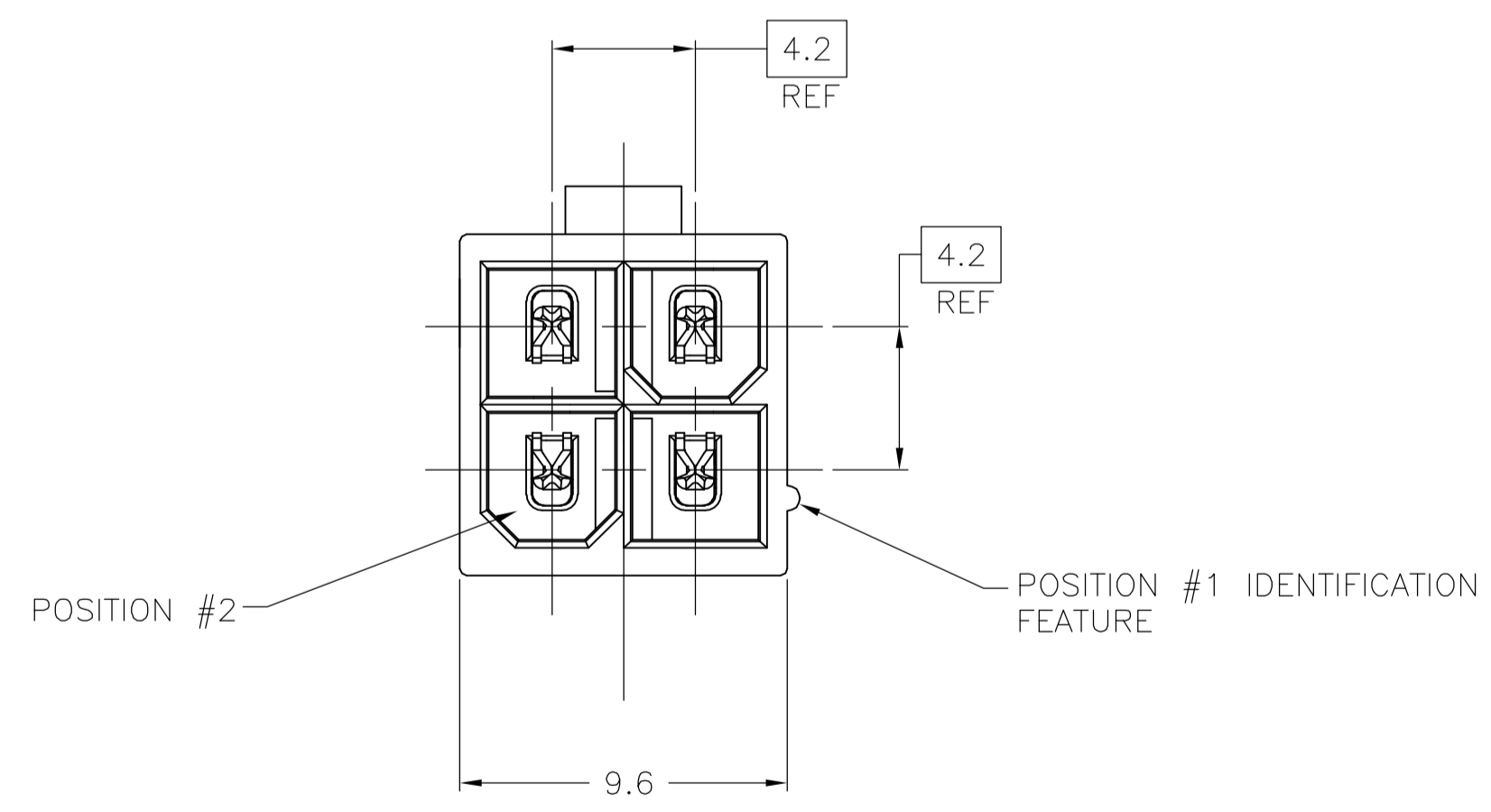

	1	10	1	1	1-794350-2
	1	9	1	1	1-794350-1
SUPERCEDED BY 1-794350-2	1	3	1	1	794350-2
SUPERCEDED BY 1-794350-1	1	2	1	1	794350-1
	MATERIAL	FINISH	MATERIAL	COLOR	PART NO.

THIS DRAWING IS A CONTROLLED DOCUMENT.		DIN R VESTAL 03JUN98	Tyco Electronics Corporation Harrisburg, Pa 17105-3608	
DIMENSIONS: mm		CHK R SWING 03JUN98	APVD C CASH 03JUN98	
TOLERANCES UNLESS OTHERWISE SPECIFIED:		NAME: ASSEMBLY, HEADER, VERTICAL, 4 POSITION, W/ DRAIN HOLES, 94V-2, AMP-DUAC		
0 PLC ± -		PRODUCT SPEC: 108-1699		
1 PLC ± 0.2		APPLICATION SPEC: -		
2 PLC ± 0.13		SIZE: A1		
3 PLC ± -		CAGE CODE: 00779		
4 PLC ± -		DRAWING NO: 794350		
ANGLES ± ± 0.30°		RESTRICTED TO: -		
MATERIAL: SEE TABLE	FINISH: SEE TABLE	WEIGHT: -	CUSTOMER DRAWING	
		SCALE: 5:1	SHEET: 1 OF 1	REV: C